

P-PI-1575C



Standard Features:

- ../ Side mounted self contained cabinet with fan forced evaporator cooling
- ../ Stainless steel with fully covered interior surfaces designed for easier cleaning and maintenance
- ../ Swivel and brake castors
- ../ doors with easy to clean handles and spring door closers
- ../ Replaceable magnetic gaskets
- ../ Removable / interchangeable pots
- ../ Plumbing-free design using self evaporating drainage
- ../ Low noise / high efficiency Danfoss compressor automatic defrost and ESM fan for the condenser
- ../ CFC free refrigerant and insulation foam
- ../ Temperature setting is easy, fast and accurate with a Carel digital temperature control panel with LED display mounted on cabinet exterior
- ../ 2 years parts and 1 year labour warranty
- ../ Fully insulated glass display with anti-fog demisters



SPECIFICATIONS	
Dimensions (w x d x h)	ISO0mm x 750mm x 950
Operating Conditions	0°C- 5°C (32 C Ambient)
Capacity	366L
Voltage	220"240 /so
Power	0.6KW
No. of Doors	2
Weight	160KG

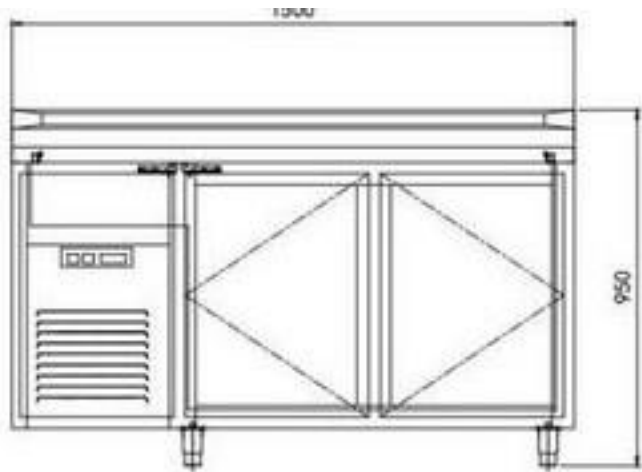

Front View

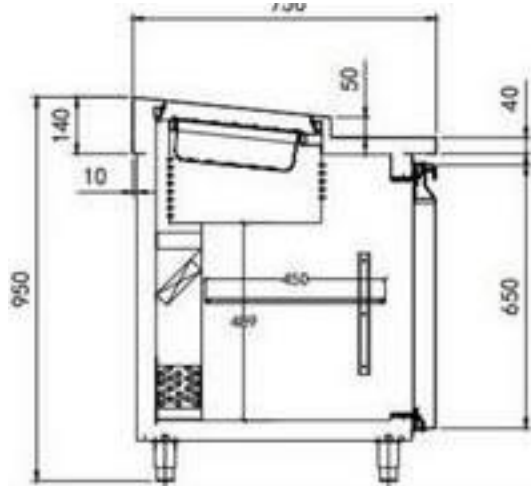

Side View